

**WARNUNG**

Gefahr des Verlusts der Text-Bild-Zuordnung beim Ausdruck.

- **Aus technischen Gründen kann derzeit nicht ausgeschlossen werden, dass trotz einwandfreier Darstellung auf dem Bildschirm beim Ausdruck der Zusammenhang von Text und zugehörigem Bild verloren geht.**
- **Wird der Fehler nicht bemerkt, besteht die Gefahr, daß Arbeiten nicht korrekt durchgeführt werden und es dadurch zu Personen- und Sachschäden kommt.**

→ Vergleichen Sie deshalb nach dem Druckvorgang unbedingt die Ausdrücke mit der Bildschirmdarstellung. Korrigieren Sie die Ausdrücke im Fehlerfall so, daß der Inhalt der Bildschirmdarstellung zutreffend wiedergegeben wird.

**WARNING**

Danger of losing text-figure correspondence when printing out.

- **For technical reasons, it can currently not be ruled out that the correspondence between text and associated figure can be lost when it is printed out, even though the display on the screen is correct.**
- **If the fault is not noticed, there is the danger that work will not be performed correctly which can cause injury and damage.**

→ Therefore, always compare printouts with the screen display after printing them out. Correct the printouts if they are faulty so that the content of the screen display matches that on the printouts.

**AVERTISSEMENT**

Risque de perte de la correspondance texte-illustration lors de l'impression papier.

- **Pour des raisons techniques, il ne peut pas être exclu à l'heure actuelle que, même en cas d'affichage correct à l'écran, la correspondance entre le texte et l'illustration puisse être erronée sur l'impression papier.**
- **Si l'erreur passe inaperçue, on court le risque d'exécuter certaines opérations de manière incorrecte pouvant conduire à des dommages corporels et matériels.**

→ Comparez impérativement pour cette raison les impressions papier avec l'affichage à l'écran.

Corrigez-les en cas d'erreur de manière à reproduire correctement l'affichage à l'écran.



ATTENZIONE

Pericolo di perdita dell'abbinamento testo-immagine nella stampa.

- **Per motivi tecnici non è escluso che, nonostante la rappresentazione sullo schermo risulti perfetta, durante la stampa venga persa la corrispondenza fra testo e relativa immagine.**
- **Se tale difetto non viene rilevato vi è il pericolo che i lavori non siano eseguiti correttamente; ciò può avere come conseguenza lesioni e danneggiamenti.**

→ Per questo motivo, dopo la stampa è assolutamente necessario confrontare le stampe con la rappresentazione sullo schermo. In caso di errore si prega di correggere le stampe, così da garantire la riproduzione esatta della rappresentazione sullo schermo.



ADVERTENCIA

Al imprimir se corre el riesgo de perder la correcta asignación de las figuras al texto.

- **Por motivos técnicos, por el momento no se puede descartar que, aun siendo correcta la imagen que aparezca en la pantalla, al imprimir se pierda la correlación entre el texto y la figura correspondiente.**
- **Si este error pasara desapercibido, existe el riesgo de que los trabajos no se ejecuten de forma correcta y, por tanto, se produzcan daños personales y materiales.**

→ Por ello le rogamos que tras el proceso de impresión compare siempre las copias impresas con la imagen de la pantalla. En caso de error, corrija las copias impresas de forma que se correspondan con el contenido de la imagen de la pantalla.

97 10 19 Removing and installing vehicle electrical system control unit - as of MY 2003

- [Preliminary work](#)
- [Removing vehicle electrical system control unit](#)
- [Installing vehicle electrical system control unit](#)
- [Subsequent work](#)
- [Coding the vehicle electrical system control unit](#)

Preliminary work

Remove cover under left instrument panel. → 702219 Removing and installing cover under instrument panel - chapter on "removing"

Removing vehicle electrical system control unit

Installation Location:

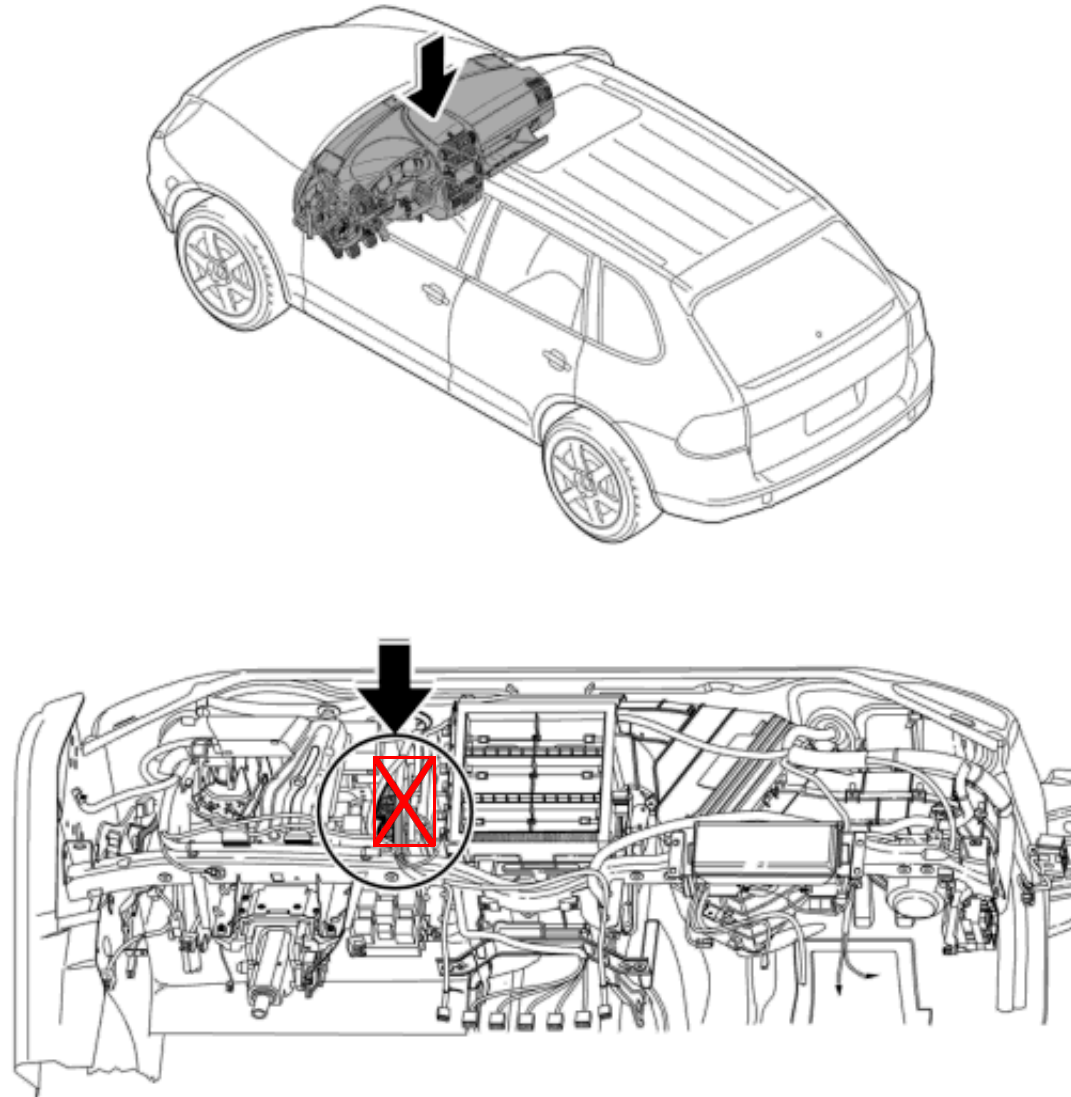

Overview of vehicle electrical system control unit

1. Remove ignition key.

2. Pull control unit slightly downwards out of the holder.

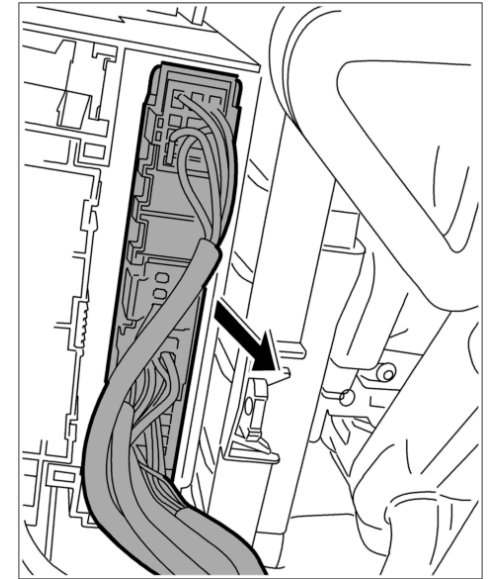

Removing vehicle electrical system control unit

3. Release and remove bottom plugs. Pull control unit completely out of the holder.

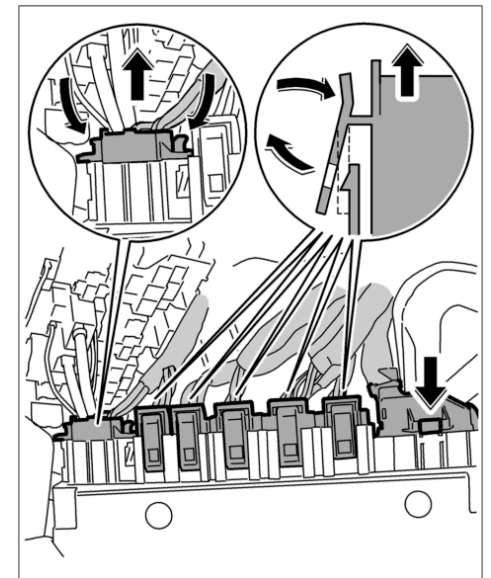

Pulling off bottom plugs

4. Release and remove top plugs.

5. Remove control module.

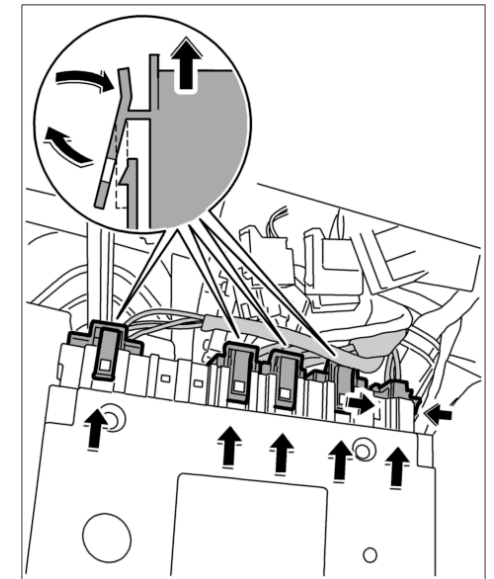

Pulling off top plugs

Installing vehicle electrical system control unit

1. Push on top row of plugs until they are felt to engage.

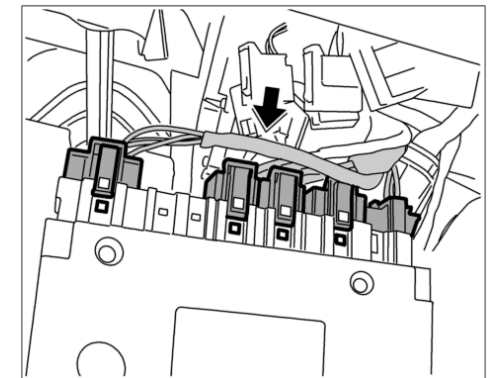

Connecting top plugs

2. Push on bottom row of plugs until they are felt to engage.
3. Push control unit upwards into the holder, making sure it engages. Make sure the electrical leads are not pinched.

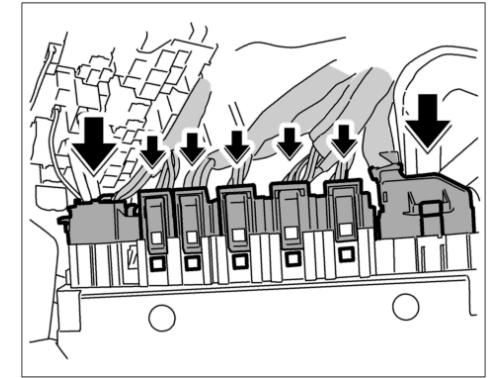

Connecting bottom plugs

Subsequent work

Install cover under left instrument panel. → 702219 Removing and installing cover under instrument panel - chapter on "installing"

Coding the vehicle electrical system control unit



Note

- If the control unit for the vehicle electrical system is replaced, it must be programmed using the Porsche System Tester. This will ensure that the control module is taught for the relevant vehicle, country version and equipment.
- If possible, before the control module is removed and replaced, a read-out of the vehicle data should be obtained using the Porsche System Tester.
- During coding, it is essential to guarantee the power supply for the Porsche System Tester. It is essential to connect a battery charger with a current rating of at least 40 A to the vehicle battery.
- Symbol for the Tab key = `?|`
- The Porsche System Tester instructions take precedence and in the event of a discrepancy these are the instructions that must be followed. Deviations may occur with later software versions.
- The procedure described here has been structured in general terms; different text or additions may appear in the Porsche System Tester.

1. Connect the Porsche System Tester to the vehicle and start the System Tester. Switch on ignition. Press `>>` to continue.

2. Select vehicle type using the cursor keys.
3. Using the **?** key, move from the vehicle type to the control modules.
4. Select Vehicle electrical system with the cursor keys and press the **>>** key.
5. Select Control unit replacement with the cursor keys and press the **>>** key.
6. Select Read out values (codings) with the cursor keys and press the **>>** key.
7. The message "Reading code" will appear on the screen of the Porsche System Tester. Press the **>>** key.
8. Switch off the ignition and replace the vehicle electrical system control unit. → 971019 Removing and installing vehicle electrical system control unit - chapter on "Removing"
9. After replacement of the vehicle electrical system control unit, the vehicle data is installed under the menu Write in data (see Section 6). Press the **>>** key.
10. System Tester displays Coding write-in complete . Press the **>>** key.
11. Quit menu, switch off ignition, lock vehicle and read out fault memory. If necessary erase fault memory.

If faults still remain after erasing, proceed in accordance with Repair Group 9710 Technical Manual, Diagnosis.

9PAAD1, 9PAAD7, 9PAAE1, 9PAAE7, 9PAAF1

as of MY 2003

Country C00, C02, C05, C07, C08, C09, C10, C11, C12, C13, C14, C15, C16, C18, C19, C20, C21, C22, C23, C24, C25, C26, C27, C28, C32, C33, C34, C35, C36, C37, C38, C39, C45, C46, C98, C99