

**WARNUNG**

**Gefahr des Verlusts der Text-Bild-Zuordnung beim Ausdruck.**

- **Aus technischen Gründen kann derzeit nicht ausgeschlossen werden, dass trotz einwandfreier Darstellung auf dem Bildschirm beim Ausdruck der Zusammenhang von Text und zugehörigem Bild verloren geht.**
- **Wird der Fehler nicht bemerkt, besteht die Gefahr, daß Arbeiten nicht korrekt durchgeführt werden und es dadurch zu Personen- und Sachschäden kommt.**

→ Vergleichen Sie deshalb nach dem Druckvorgang unbedingt die Ausdrücke mit der Bildschirmdarstellung. Korrigieren Sie die Ausdrücke im Fehlerfall so, daß der Inhalt der Bildschirmdarstellung zutreffend wiedergegeben wird.

**WARNING**

**Danger of losing text-figure correspondence when printing out.**

- **For technical reasons, it can currently not be ruled out that the correspondence between text and associated figure can be lost when it is printed out, even though the display on the screen is correct.**
- **If the fault is not noticed, there is the danger that work will not be performed correctly which can cause injury and damage.**

→ Therefore, always compare printouts with the screen display after printing them out. Correct the printouts if they are faulty so that the content of the screen display matches that on the printouts.

**AVERTISSEMENT**

**Risque de perte de la correspondance texte-illustration lors de l'impression papier.**

- **Pour des raisons techniques, il ne peut pas être exclu à l'heure actuelle que, même en cas d'affichage correct à l'écran, la correspondance entre le texte et l'illustration puisse être erronée sur l'impression papier.**
- **Si l'erreur passe inaperçue, on court le risque d'exécuter certaines opérations de manière incorrecte pouvant conduire à des dommages corporels et matériels.**

→ Comparez impérativement pour cette raison les impressions papier avec l'affichage à l'écran. Corrigez-les en cas d'erreur de manière à reproduire correctement l'affichage à l'écran.

**ATTENZIONE**

**Pericolo di perdita dell'abbinamento testo-immagine nella stampa.**

- **Per motivi tecnici non è escluso che, nonostante la rappresentazione sullo schermo risulti perfetta, durante la stampa venga persa la corrispondenza fra testo e relativa immagine.**
- **Se tale difetto non viene rilevato vi è il pericolo che i lavori non siano eseguiti correttamente; ciò può avere come conseguenza lesioni e danneggiamenti.**

→ Per questo motivo, dopo la stampa è assolutamente necessario confrontare le stampe con la rappresentazione sullo schermo. In caso di errore si prega di correggere le stampe, così da garantire la riproduzione esatta della rappresentazione sullo schermo.

**ADVERTENCIA**

**Al imprimir se corre el riesgo de perder la correcta asignación de las figuras al texto.**

- **Por motivos técnicos, por el momento no se puede descartar que, aun siendo correcta la imagen que aparezca en la pantalla, al imprimir se pierda la correlación entre el texto y la figura correspondiente.**
- **Si este error pasara desapercibido, existe el riesgo de que los trabajos no se ejecuten de forma correcta y, por tanto, se produzcan daños personales y materiales.**

→ Por ello le rogamos que tras el proceso de impresión compare siempre las copias impresas con la imagen de la pantalla. En caso de error, corrija las copias impresas de forma que se correspondan con el contenido de la imagen de la pantalla.

## 57 09 19 Removing and installing lock cylinder - as of MY 2003

- [Removing lock cylinder](#)

- [Installing lock cylinder](#)

### Removing lock cylinder

### Removing lock cylinder

**Installation Location:**

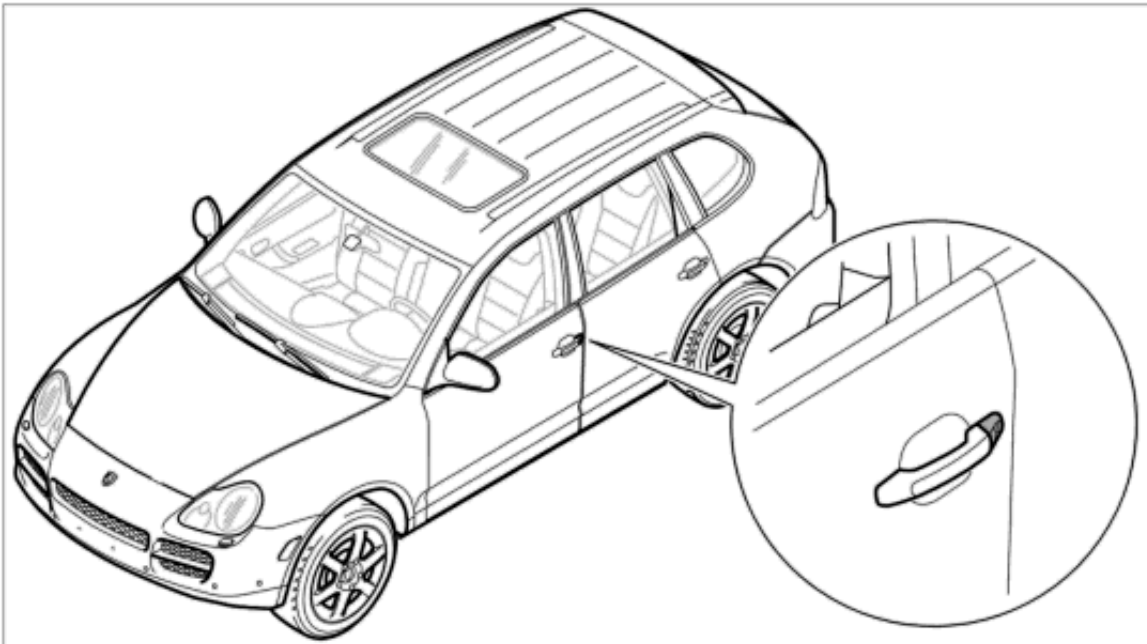

1. Open door.
2. Unclip cap.
  - 2.1. Unclip lower cap **-1-** with a plastic wedge ( **-arrow A-** ) and remove downwards **-arrow B-** .

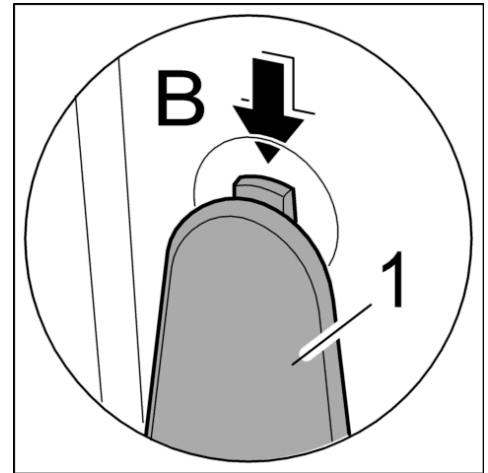
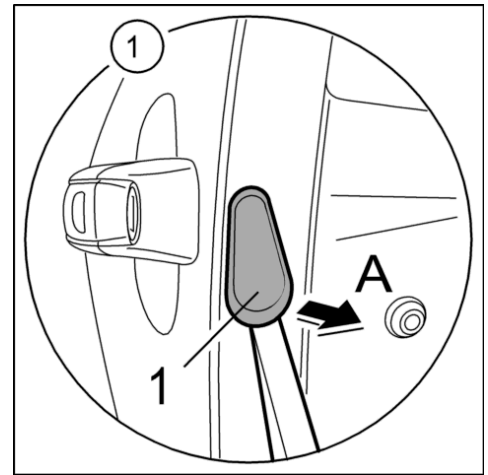

### 3. Remove lock cylinder.

3.1. Loosen and unscrew fastening screws **-2, 3-** at the side until the lock cylinder **-4-** can be pulled out **-arrow C-**.

3.2. Remove the lock cylinder **-4-** **-arrow D-**.

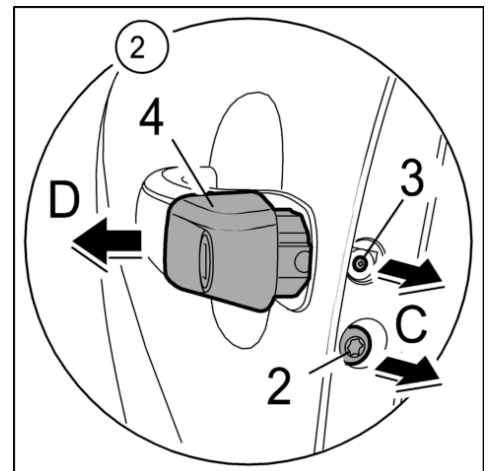

### 4. Unclip lock cylinder cover.

4.1. Unclip cover **-5-** of lock cylinder **-4-** at the locking tabs **-Arrows-** and remove it **-arrow E-**.

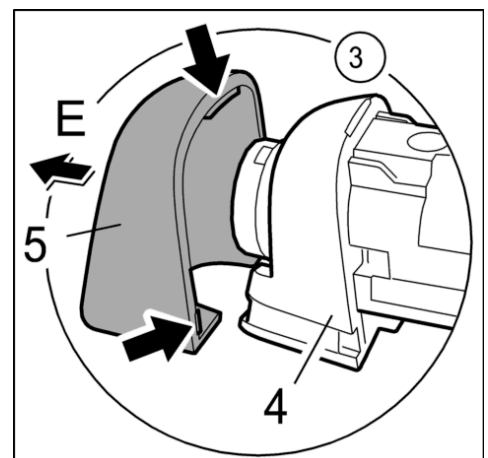

## Installing lock cylinder

### Installing lock cylinder

#### Installation Location:

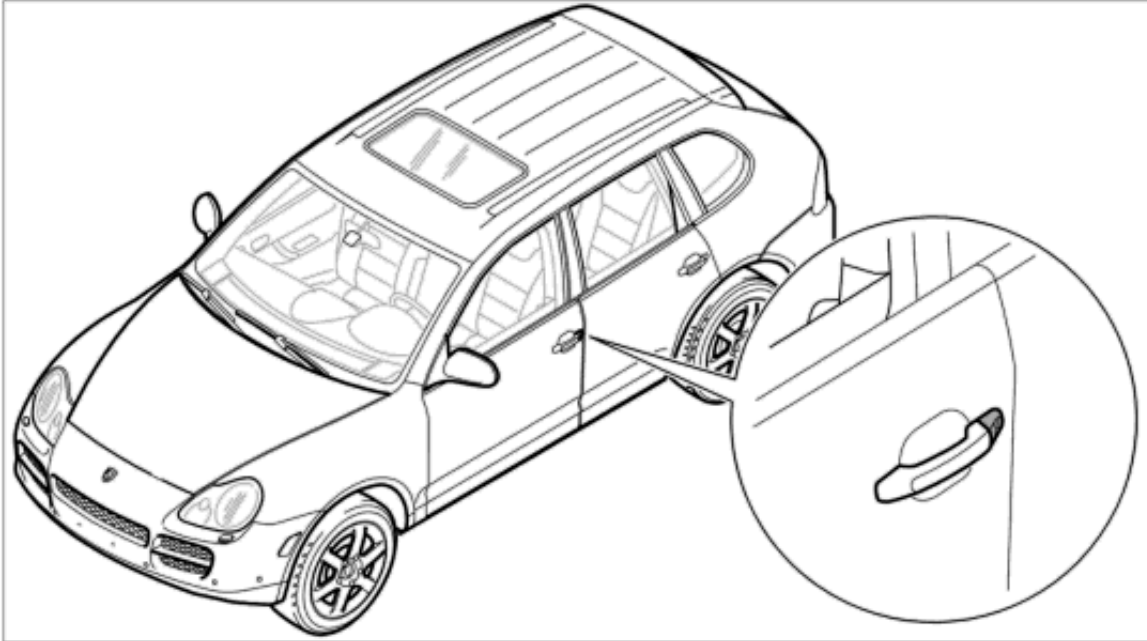

1. Clip in lock cylinder cover.
  - 1.1. Press cover **-5-** of lock cylinder **-4-** on **-arrow A-**, until locking tabs **-arrows-** engage.

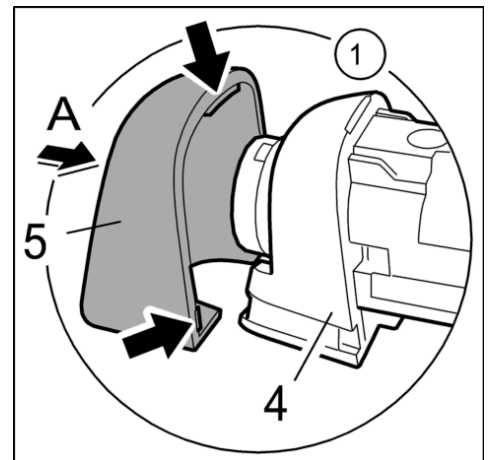

2. Install lock cylinder.
  - 2.1. Insert the car key into the lock cylinder and push the lock cylinder in **-4- arrow B-**, turning the car key slightly to the right. Loosen fastening screws **-2 and 3-** slightly, if necessary, until the lock cylinder can be pushed in completely.
  - 2.2. Screw in fastening screws **-2, 3-** at the sides **-arrows C-** and tighten them to the specified tightening torque → **Tightening torque: 3.5 ftlb. +/-0.5 ftlb. → Tightening torque: 0.5 ftlb. .**

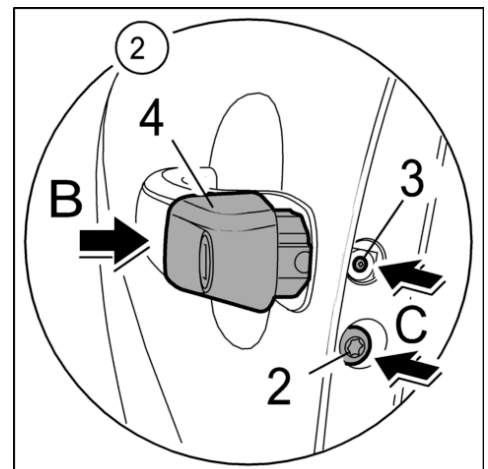

3. Clip cap into place.

- 3.1. Insert cap **-1-** at the top **-arrow D-** and clip it into position **-arrow E-**.

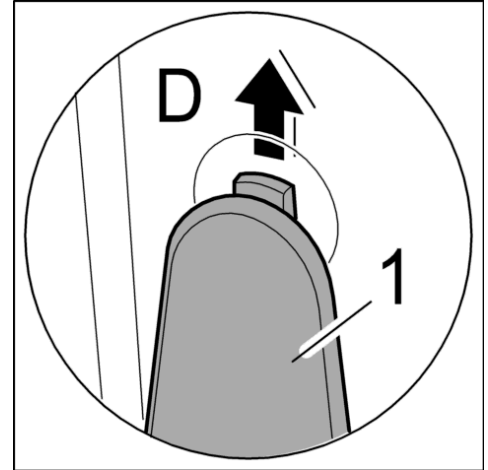
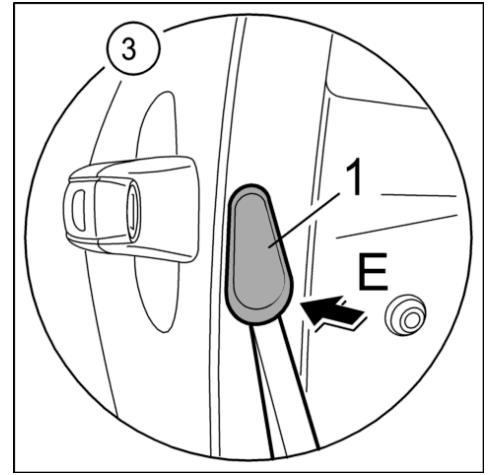

9PAAD1, 9PAAD7, 9PAAE1, 9PAAE7, 9PAAF1, 9PAAJ1

as of MY 2003

Country C00, C02, C05, C07, C08, C09, C10, C11, C12, C13, C14, C15, C16, C18, C19, C20, C21, C22, C23, C24, C25, C26, C27, C28, C32, C33, C34, C35, C36, C37, C38, C39, C45, C46, C98, C99